

Brew Master RO Package Data Sheet

Models:

This Data Sheet covers the RainDance Water Systems line of Brew Master RO packages from 400-1,500 GPD models.

Design:

A complete package to serve breweries, distilleries, and craft beverage makers with clean water, designed to remove impurities from municipal and well water sources. Features low waste technology, TDS blending, and pressure boosting for high efficiency operation.

Specifications:

All 400-1,500GPD Packages include the following specifications. Individual equipment specifications can be found later in the document.

Power: 120v, 60hz Standard Receptacle

Water Pressure: Minimum 25psi / Maximum 100psi

Water Temperature: Minimum 39F / Maximum 100F (3.9C / 37.7C)

Port Sizes:

1/2" FNPT (Prefilter Inlet)

1/2" QC (RO/Remineralizer, Tubing Supplied)

2" FNPT (Storage Tank Outlet)

1" FNPT (Pump Inlet/Outlet)

Options:

Add-ons included with the listed packages:

TDS Blending: Adds a precise amount of TDS back to the purified water to provide a partial mineral content for specific beverages.

Storage Tank: Large atmospheric tank holds a high volume of water for on-demand home use.

Delivery Pump: Provides pressurized water to all taps in the building.



*RainDance Water Systems Products are
Built in the USA by American Workers
utilizing Domestic and Foreign Parts.*



1672 Main St Suite E312, Ramona, CA 92065 USA - www.raindancewater.com
 Ph: 877-788-8387 | Ph: 760-788-8387 - sales@raindancewater.com

Reverse Osmosis Data Sheet

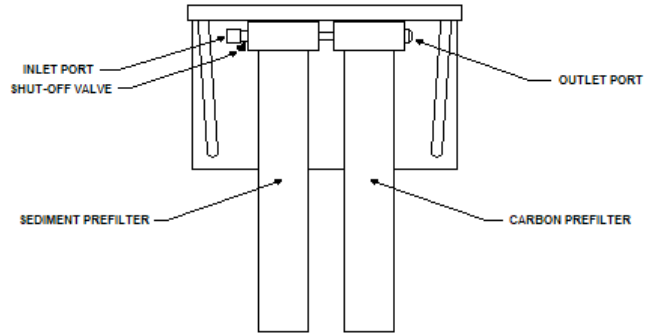
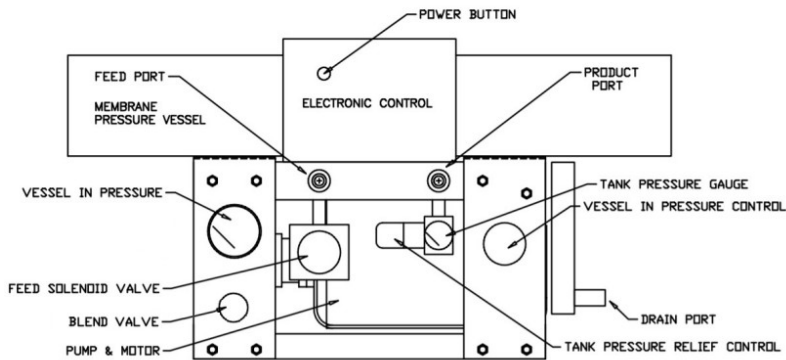

	400 GPD	800 GPD	1200 GPD	1500 GPD
Frame	Stainless Steel, No. 4 Finish			
Membranes	1 2521 Thin Film	1 4021 Thin Film	1 4021 Thin Film	1 4040 Thin Film
Filters	Dual 2.5" x 10" Sediment & Carbon	Dual 2.5" x 20" Sediment & Carbon		
Electrical	110/120v 60Hz, 1-ph., 10.4A			
Motor	1/3 HP, 1725 RPM Drip Proof, Thermally Protected	3/4 HP, 1725 RPM, Drip Proof, Thermally Protected		
Feed/Drain/ Product Connections	1/2" Quick Connect Fittings			
Capacity*	0.3gpm, 400gpd	0.6gpm, 800gpd	0.8gpm, 1200gpd	1.1gpm, 1500gpd
Min/Nominal/Max Operating Pressure	25/150/200 psi			
Recovery w/ Recirculation Valve	50%			
Typical Rejection	98.00%			
Max Feed TDS	2500ppm			
Max. Chlorine	<0.1ppm			
Overall Dimensions (w/ Attached Filters)	28"W x 8"D x 12"H (25"H)	30"W x 8"D x 14"H (37"H)		45"W x 8"D x 14"H (37"H)
Weight	55 lbs.	60 lbs.		65 lbs.

*Production varies based on water temperature and TDS level. Colder water/higher TDS will decrease production.



1672 Main St Suite E312, Ramona, CA 92065 USA - www.raindancewatersystems.com
 Ph: 877-788-8387 | Ph: 760-788-8387 - sales@raindancewatersystems.com

Storage Tank Data Sheet

	200 Gallon	300 Gallon	500 Gallon
Material	Polyethylene – BPA Free		
Connections	1/2" Quick Connect Fitting (Inlet) – 2" FNPT (Outlet)		
Overall Dimensions	31"D x 72"H	35"D x 81"H	46"D x 76"H
Weight	Approx. 70 lbs.	Approx. 80 lbs.	Approx. 110 lbs.

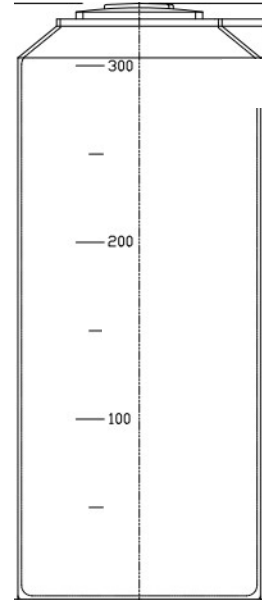

Delivery Pump Data Sheet

	10 GPM
Power	1 HP
Electrical	110/120v 60Hz, 1-ph., 10.0A
Connections	1" FNPT Inlet/Outlet
Capacity	10 GPM @ 48psi
Overall Dimensions	16"L x 7"W x 9"H
Weight	Approx. 25 lbs.

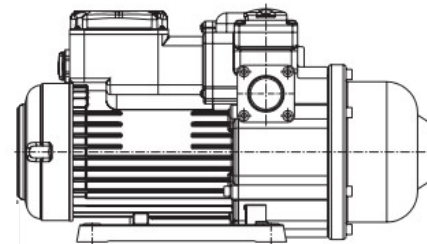



1672 Main St Suite E312, Ramona, CA 92065 USA - www.raindancewatersystems.com
 Ph: 877-788-8387 | Ph: 760-788-8387 - sales@raindancewatersystems.com

RainDance Brew Master RO Optional Equipment

RainDancePRO Pretreatment System Data Sheet

	RainDancePRO-125-10
Filter Type	Water Softener & Well Water Filter
Electrical	110/120v 60hz, 1-ph., 1.0A
Connections	1" MNPT Inlet/Outlet, 1/2" Barb Drain
Pretreat Lockout	Automatic switch to shut down RO system during regeneration.
Capacity	Max. Flow Rate: 15 gpm
Overall Dimensions	Filter Tank: 10"D x 63"H Brine Tank: 18"D x 40"H
Weight	Approx. 135 lbs.

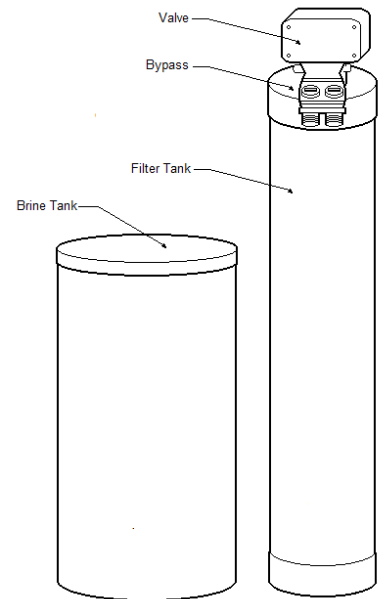

Post UV System Data Sheet

	400 GPD	800-1500 GPD
Filter Type	Ultraviolet Light Bacteria Disinfection	
Electrical	110/120v 60hz, 1ph., 0.3A	
Connections	3/4" - 1" MNPT COMBO	
Capacity	Chamber: 3.5"D x 17.75"L Controller: 6.8"L x 3.2"W x 2.5"H	
Overall Dimensions	5"D x 15"H	
Weight	Approx. 12 lbs.	

