



Brew Master RO Packages

by RainDance Water Systems

RainDance Water Systems Compact Reverse Osmosis Systems

successfully purifies water with dissolved minerals and metals such as **aluminum, arsenic, barium, cadmium, chloride, chromium, copper, fluoride, Gen-X, lead, mercury, nitrate, PFAS, selenium, silver, sodium, sulfates, and zinc**. RO is also effective with **asbestos, many taste, color, and odor-producing chemicals, particulates, total dissolved solids, turbidity, uranium, and radium**.

*Our Brew Master RO Packages include sediment & activated carbon prefilters which provide additional treatment for **sediment, dirt, debris, chlorine, chloramine, "volitale" contaminants (VOCs) such as trichloroethylene, trihalomethanes, pesticides, and radon**. An exclusive **TDS Blending Option** is included to allow the brewer to craft their own mineral content by adding their desired amount of TDS back to the water for a specific taste that's unique to your brew!*

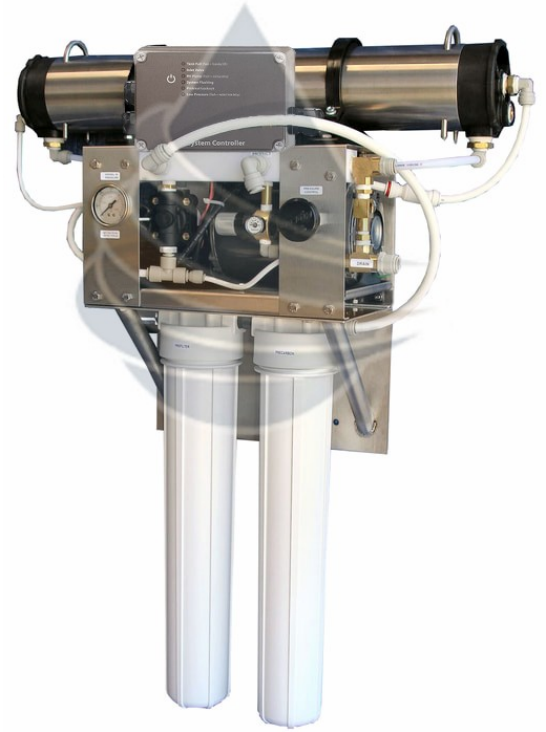

Find out what makes our Brew Master RO Package the most unique commercial purification on the market today!

RainDance Water Systems Brew Master RO Package Brochure

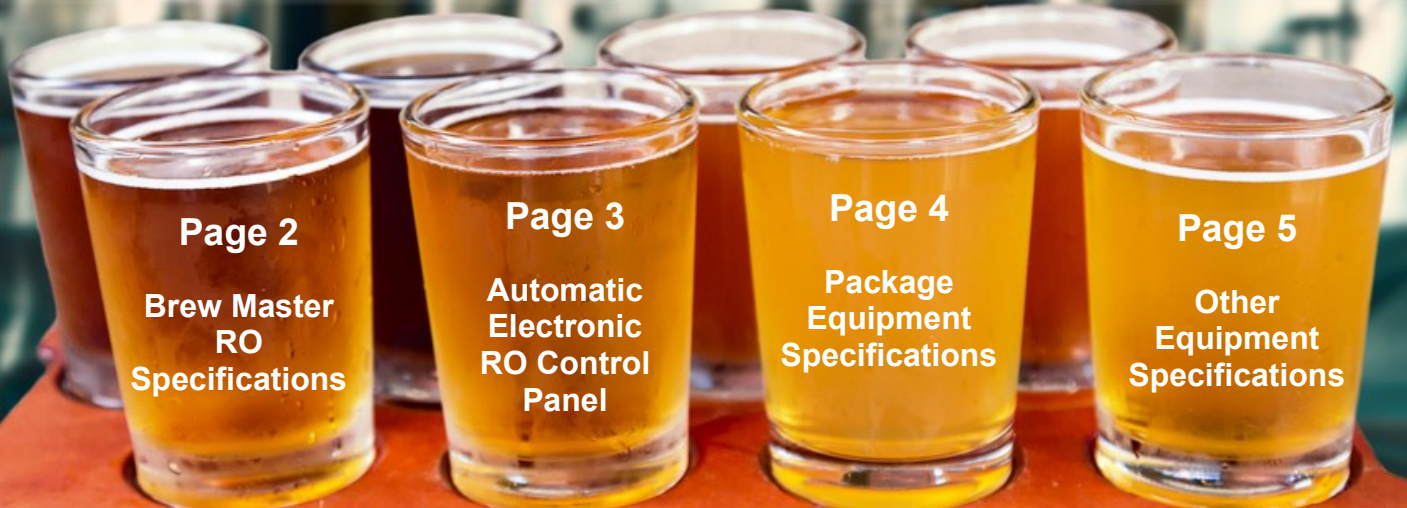



1672 Main St. Suite E312, Ramona, CA 92065 USA - www.raindancewatersystems.com
 Ph: 877-788-8387 | Ph: 760-788-8387 - sales@raindancewatersystems.com

RainDance Brew Master RO Packages

Our high performance Brew Master RO series features our premium wall mounted stainless steel reverse osmosis system with attached sediment and carbon prefilters for extra protection against dirt, debris, chlorine, chloramine, organic chemicals, and VOCs. Along with our durable RO system these custom Brew Master RO packages include a TDS blending valve, your choice of storage tank, and 10gpm repressurization delivery pump for pressurized purified water.

**Appearances may vary from picture*



RainDance-400 Brew Master RO	RainDance-800 Brew Master RO	RainDance-1200 Brew Master RO	RainDance-1500 Brew Master RO
400 GPD Capacity	800 GPD Capacity	1,200 GPD Capacity	1,500 GPD Capacity
28"W x 8"D x 25"H	30"W x 8"D x 37"H	30"W x 8"D x 37"H	45"W x 8"D x 37"H
Treats up to 2,500ppm TDS	Treats up to 2,500ppm TDS	Treats up to 2,500ppm TDS	Treats up to 2,500ppm TDS
1:1 Product/Waste Ratio	1:1 Product/Waste Ratio	1:1 Product/Waste Ratio	1:1 Product/Waste Ratio
Integrated Fast Flush	Integrated Fast Flush	Integrated Fast Flush	Integrated Fast Flush
Works with City & Well Water Sources	Works with City & Well Water Sources	Works with City & Well Water Sources	Works with City & Well Water Sources
Wet Tested Before Shipping	Wet Tested Before Shipping	Wet Tested Before Shipping	Wet Tested Before Shipping
Shop Now!	Shop Now!	Shop Now!	Shop Now!

Premium Reverse Osmosis System Specifications

- Stainless Steel Frame & Vessels – provides long-lasting, durable, and reliable structural integrity.
- On / Off Switch for emergency/manual system control.
- Low Energy Semipermeable Membrane
- Attached Sediment & Carbon Prefilters
- **High Recovery Recirculation Valve** – Provides high recovery / low waste 50% (1:1 Ratio) Recovery
- Fast Flush Membrane Feature - provides a momentary high velocity flow across the membrane to help flush away any accumulated particles or debris.
- **RO Accessories Included:** Color-Coded Tubing, Water Totalizing Meter, Handheld TDS Meter, Replacement Consumable Pack, Preloaded Flash Drive w/ Instructions, Diagrams, Manuals, and more.
- Dissolved Solids Rejection: 98%
- Power Req.: 110v 60hz, 1-phase
- **Operating Parameters:** Max TDS 2500ppm; Total Iron is less than 0.3ppm; Manganese is less than 0.05ppm; Water Hardness below 5 gpg **Production varies based on water temperature and TDS level. Colder water/higher TDS will decrease production.*

Automatic Electronic RO Control Panel

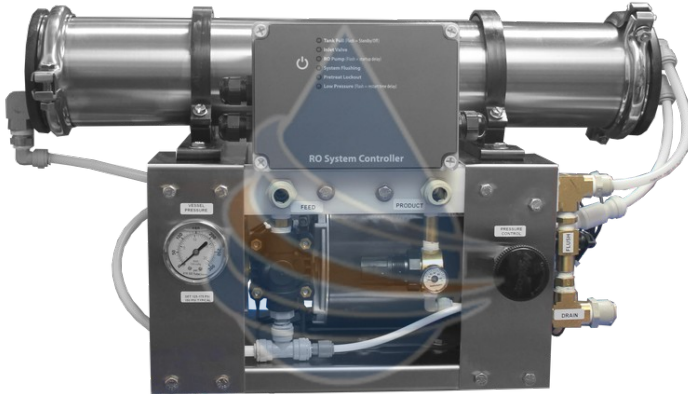

Easy Automatic RO Control Panel now included with the RainDance Brew Master RO Packages. Our integrated electronic controller offers automated control of several system functions and helps prolong the life of the RO motor and membrane, providing long-term and reliable operation. Built with superior engineering, this control panel eliminates confusing switches and lack of feedback provided by other generic RO systems.

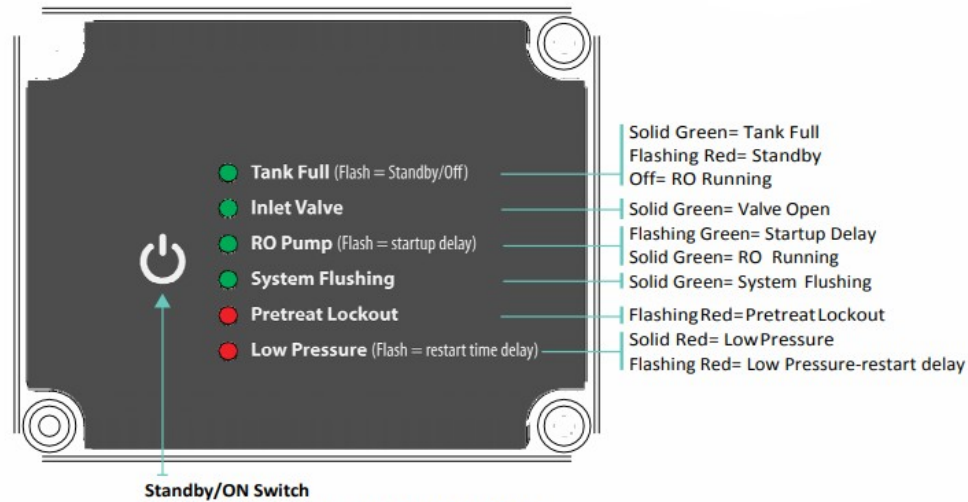

The Automatic RO Control Panel allows the business owner to easily monitor the performance of their system by using easy-to-read light up indicators for common RO functions. Certain features such as the System Flushing and Low Pressure provide added protection by automatically cleaning the RO membrane and shutting the RO system off in events of low water pressure. Low water pressure can cause an RO system to cycle on and off which can burn out the motor and increase noise level. Other features like the RO Pump and Tank Full keep you informed when the system is running and you have a full tank of purified water. With automated control it has never been easier to operate a reverse osmosis system!

Package Equipment Specifications



Sediment & Carbon Pretreatment System

Stainless Steel Dual Sediment and Carbon Prefiltration System w/ Shutoff Valve.

Features:

- Protects RO from sediment, debris, chlorine, chloramine, chlorination by-products, organic chemicals, herbicides, pesticides, insecticides, and more.
- Dimensions: 14"W x 8"D x 12"H (400) – 14"W x 8"D x 23"H (800-1500)

TDS Blending Valve

This built-in feature allows the brewer to craft their specific beverage with a precise amount of TDS in the final product water. Pre-installed with a needle valve and TDS sensor for accurate TDS blending.

Features:

- Needle valve with knob for controlling TDS level.
- TDS sensor that shows both feed water and product water TDS content.



Atmospheric Product Storage Tank

The purified water comes out as a small stream, so a storage tank is required to collect the product water before usage. One float switch and float for system control by tank level preinstalled on RO and tank respectively. FDA/USDA Approved – BPA Free

Features:

- 200, 300, & 500 Gallon Capacities Available
- Dimensions: 31"D x 72"H (200) – 35"D x 81"H (300) – 46"D x 76"H (500)
- 10" manway, vacuum and pressure relief cap
- Fitted with inlet and outlet ports



10gpm Repressurization Delivery Pump

When there is a demand for purified water, the repressurization pump is activated and draws water from the storage tank to your applications.

Features:

- Power: 110 VAC, 1-phase, 1hp Motor
- Output: 10 gpm @ 48psi
- 1" Inlet/Outlet Ports



Optional Equipment Specifications

RainDancePRO RO Pretreatment System



The RainDancePRO is a high-performance water softener removing hard water minerals, rust, iron, and sediment from all types of water sources. This system is an automatic self-cleaning filter which regenerates based on water use to save on salt and uses high performance softening resin to continue softening for many years.

Specifications:

- Softener Tank Dimensions: 10"D x 63"H
- Brine Tank Dimensions: 18"D x 40"H
- Power: 110v, 60hz
- Plumbing Ports: 1"
- Service / Backwash Flow Rate: 15gpm / 3.5gpm
- Min/Max Pressure: 30/100psi
- Includes Pretreat Lockout Switch to protect RO system during regeneration.

Post UV Disinfection System

Add a post UV Disinfection System after the storage tank delivery pump to ensure safe, disinfected water from the standing water in the storage tank. UV disinfection offers **99.99% destruction** of bacteria, viruses, and protozoan cysts (Giardia Lamblia, Cryptosporidium).

Features:

- Chamber Dimensions: 17.75"L x 3.5"D
- 3/4"-1" Combo Inlet/Outlet Ports
- Power: 110v, 60hz



RainDance Reverse Osmosis System Accessories Include:

Color-Coded Installation Tubing, Water Totalizing Meter, Portable Handheld TDS & pH Testers, Preloaded Flash Drive, and Replacement Consumable Package

